

## Attitude and Heading Reference System

AHRS-I

Datasheet  
Revision 2.0

The **Inertial Labs Attitude and Heading Reference System, AHRS-I** is a high-performance strapdown system that determines absolute orientation (heading, pitch and roll) for any device on which it is mounted. Orientation is determined with high accuracy for both motionless and dynamic applications.



The Inertial Labs AHRS-I utilizes 3-axes each of precision accelerometers, magnetometers and gyroscopes to provide accurate Heading, Pitch and Roll of the device under measure. Integration of gyroscopes' output provides high frequency, real-time measurement of the device rotation about all three rotational axes. Accelerometers and Fluxgate magnetometer measure absolute Pitch, Roll and magnetic Azimuth at AHRS initial alignment as well as providing ongoing corrections to gyroscopes during operation.

## KEY FEATURES AND FUNCTIONALITY

- State-of-the-art algorithms for different dynamic motions of Robots, UAV, UUV, UGV, AGV, ROV, Gimbals and Antennas
- Highly accurate, sensitive, and temperature stable Fluxgate magnetometers (in-house technology)
- 0.4 deg Heading and 0.1 deg Attitude accuracy in full temperature range
- 4 deg/hr gyroscopes and 0.05 mg accelerometers Bias in-run stability
- Gyro-Stabilized Slaved Magnetic Heading
- Suitable for Primary Attitude Reference
- Advanced, extendable, embedded Kalman Filter based sensor fusion algorithms
- Embedded 2D and 3D magnetic calibration on hard and soft iron
- All solid state components (no moving parts)
- Full temperature calibration of all sensing elements
- Up to 200Hz data update rate
- Environmentally sealed (IP67)
- Compact design

One of the key elements to the success of Inertial Labs AHRS-I is its use of **Inertial Labs 8mm Fluxgate Magnetometers**.

**Inertial Labs Fluxgate Magnetometer** has distinct advantages over commonly used magneto-inductive or magneto-resistive magnetometers. In operation over time and temperature fluxgate magnetometers have superior stability and repeatability. In terms of sensitivity, fluxgate magnetometers provide up to two orders of magnitude increased sensitivity.

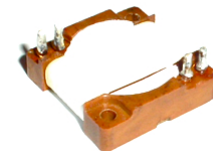

In addition to the performance advantages, unlike the chip-level magnetometer technology, fluxgate magnetometer technology has been depended on for over 70 years to provide an accurate reference to North. It remains the most reliable magnetic sensor technology for determining an object's heading.

### AHRS Specifications

Parameter	Units	Value		
Output signals		Euler angles; Quaternion; Accelerations; Angular rates; Magnetic field, Delta Theta and Delta Velocity		
Update rate	Hz	1 ... 200 (user settable)		
Start-up time	sec	< 1		
Full Accuracy Data (Warm-up Time) <sup>(1)</sup>	sec	30		
<b>Heading</b>				
Range	deg	0 to 360		
Angular Resolution	deg	0.01		
Static Accuracy in whole Temperature Range <sup>(2)</sup>	deg	0.4		
Dynamic Accuracy <sup>(3)</sup>	deg RMS	0.7		
Noise (at 200 Hz output)	deg RMS	0.03		
<b>Attitude</b>				
Range: Pitch, Roll	deg	±90, ±180		
Angular Resolution	deg	0.01		
Static Accuracy in whole Temperature Range <sup>(4)</sup>	deg	0.1		
Dynamic Accuracy <sup>(5)</sup>	deg RMS	0.3		
Noise (@100 Hz)	deg RMS	0.02		
<b>Sensors</b>				
Technology type		Accelerometers	Gyroscopes	Magnetometers
Measurement range		MEMS	MEMS	Fluxgate
Bandwidth <sup>(6)</sup>		±2 g, ±6 g	±250/500/1000/2000 deg/sec	±1.6 Gauss
Resolution		50	50	50
Bias in-run stability (RMS, Allan Variance)		0.1 mg (at ±2g range)	0.01 deg/sec (at ±250deg/sec range)	10 nT
SF accuracy		50 ug	4 deg/hr	0.1 nT
Noise density		0.1 %	0.01 %	0.02 %
Non-linearity		40 ug/Hz	0.009 deg/sec/Hz	3 uG/√Hz
Axis misalignment		0.05%	0.01%	0.02%
		0.15 mrad	0.15 mrad	0.15 mrad
<b>Environment</b>				
Operating temperature	deg C	-40 to +70		
Storage temperature	deg C	-50 to +85		
MTBF	hours	55,500		
<b>Electrical</b>				
Supply voltage <sup>(7)</sup>	V DC	+5.5 to +6.5		
Current draw in readiness mode	mA	105		
Current draw in sleep mode	mA	30		
Connector	-	6-pin Female Binder series 718 (RS-232) 8-pin Female Binder series 712 (RS-422) 8-pin Male Binder series 712 (RS-485)		
Output Interface	-	RS-232, RS-422, RS-485 and USB (with external converter)		
Output data format		Binary or NMEA 0183 ASCII characters		
<b>Mechanical</b>				
Size	mm	90 × 27 × 26		
Weight	gram	73		

<sup>(1)</sup> including time of initial alignment, it may be decreased on request.

<sup>(2)</sup> in homogeneous magnetic environment, for latitude up to ±65 deg. Heading static accuracy in whole temperature range = 0.7 deg for AHRS with ±6 g accelerometers measurement range

<sup>(3)</sup> dynamic accuracy may depend on type of motion. Heading dynamic accuracy in whole temperature range = 1.0 deg for AHRS with ±6 g accelerometers measurement range

<sup>(4)</sup> attitude static accuracy in whole temperature range = 0.2 deg for AHRS with ±6 g accelerometers measurement range

<sup>(5)</sup> dynamic accuracy may depend on type of motion. Attitude dynamic accuracy in whole temperature range = 0.5 deg for AHRS with ±6 g accelerometers measurement range

<sup>(6)</sup> Gyroscopes, accelerometers and magnetometers bandwidth can be increased up to 400Hz though with increasing of the sensors noise and noise in calculated orientation angles

<sup>(7)</sup> AHRS model with 9 to 40 V DC supply voltage is available

**Inertial Labs Attitude and Heading Reference Systems available models and part numbers**

**AHRS-I - G250/500/1000/2000 - A2/6 - TMGA - C1 - V1.1/V1.2/V1.3**

model                      gyro range                      acc range                      calibration                      case                      interfaces

Model	Gyroscopes measurement range				Accelerometers measurement range		Temperature calibration	Aluminum case	Interfaces		
	G250	G500	G1000	G2000	A2	A6	TMGA	C1	V1.1	V1.2	V1.3
+	±250 deg/sec	±500 deg/sec	±1000 deg/sec	±2000 deg/sec	±2 g	±6 g	YES	YES	RS-232	RS-422	RS-485

**AHRS mechanical interface drawing**

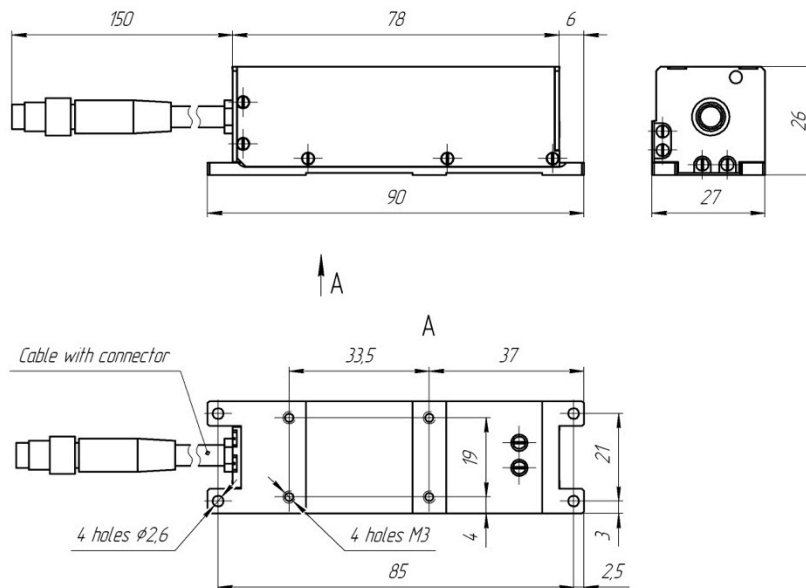

**Notes:**

1. All dimensions are in millimeters.
2. All dimensions within this drawing are subject to change without notice. Customers should obtain final drawings before designing any interface hardware.

**AHRS electrical interface description**

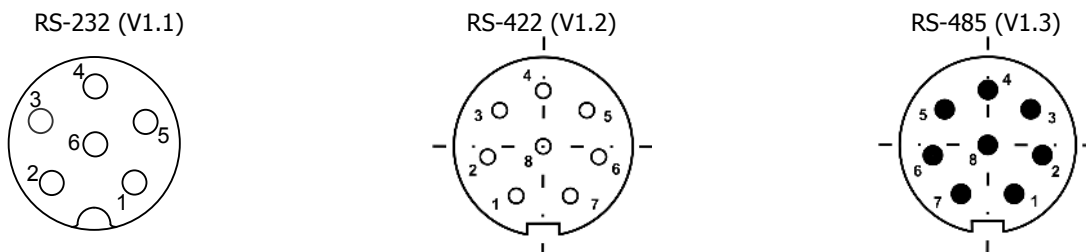

Binder Series 718 Female 6-Pin Connector		Binder Series 712 Female 8-Pin Connector		Binder Series 712 Male 8-Pin Connector	
Pin #	Signal	Pin #	Signal	Pin #	Signal
1	Do not connect	1	RS422 – A	1	RS485 – A
2	Tx	2	RS422 – B	2	RS485 – B
3	Rx	3	RS422 – Y	3	Reserved
4	GND	4	RS422 – Z	4	Reserved
5	V <sub>DD</sub>	5	GND	5	GND
6	Do not connect	6	V <sub>DD</sub>	6	V <sub>DD</sub>
-		7	Do not connect	7	Do not connect
-		8	Reserved	8	Reserved